

# Bendarc

## Assembly Instructions

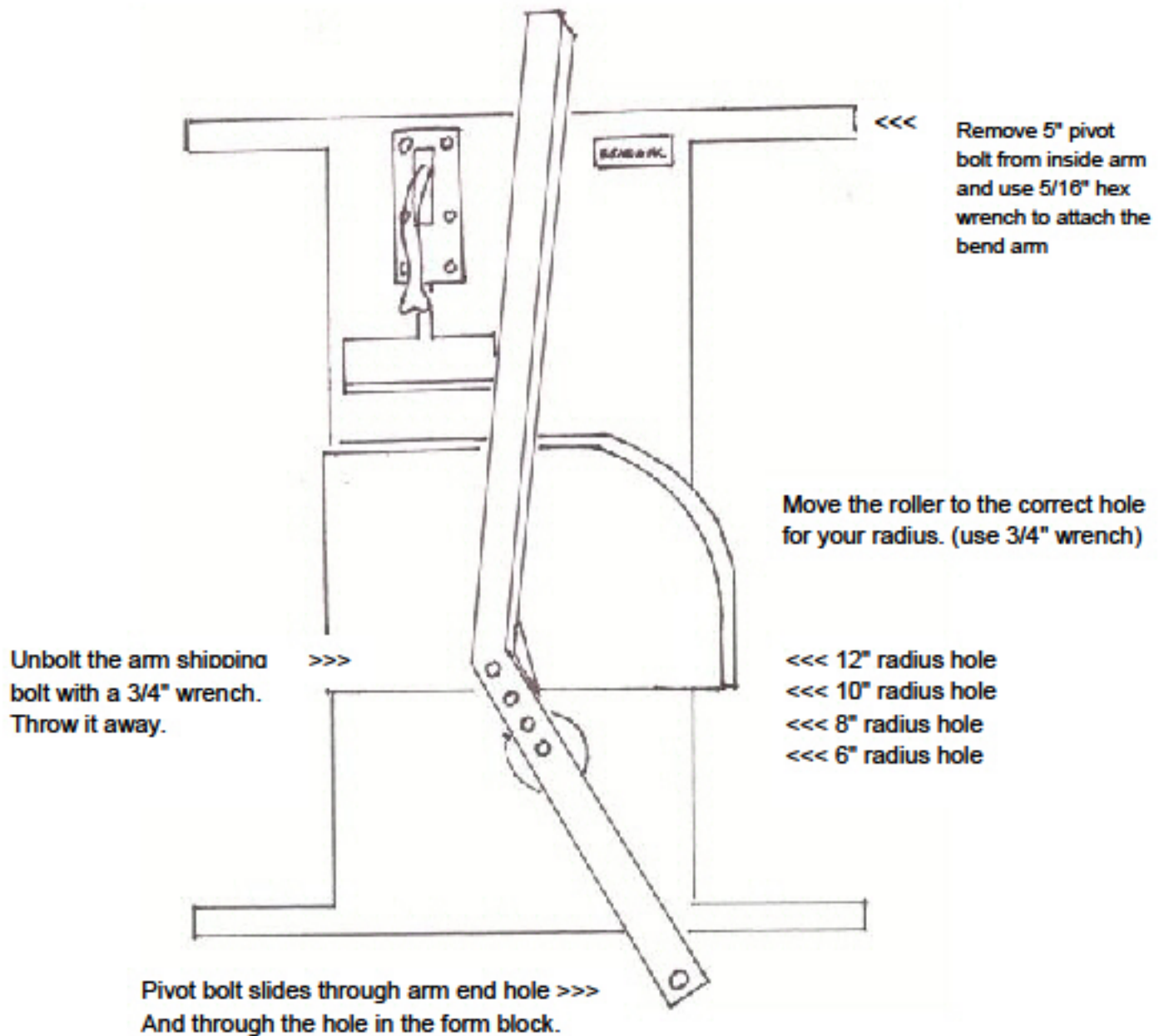

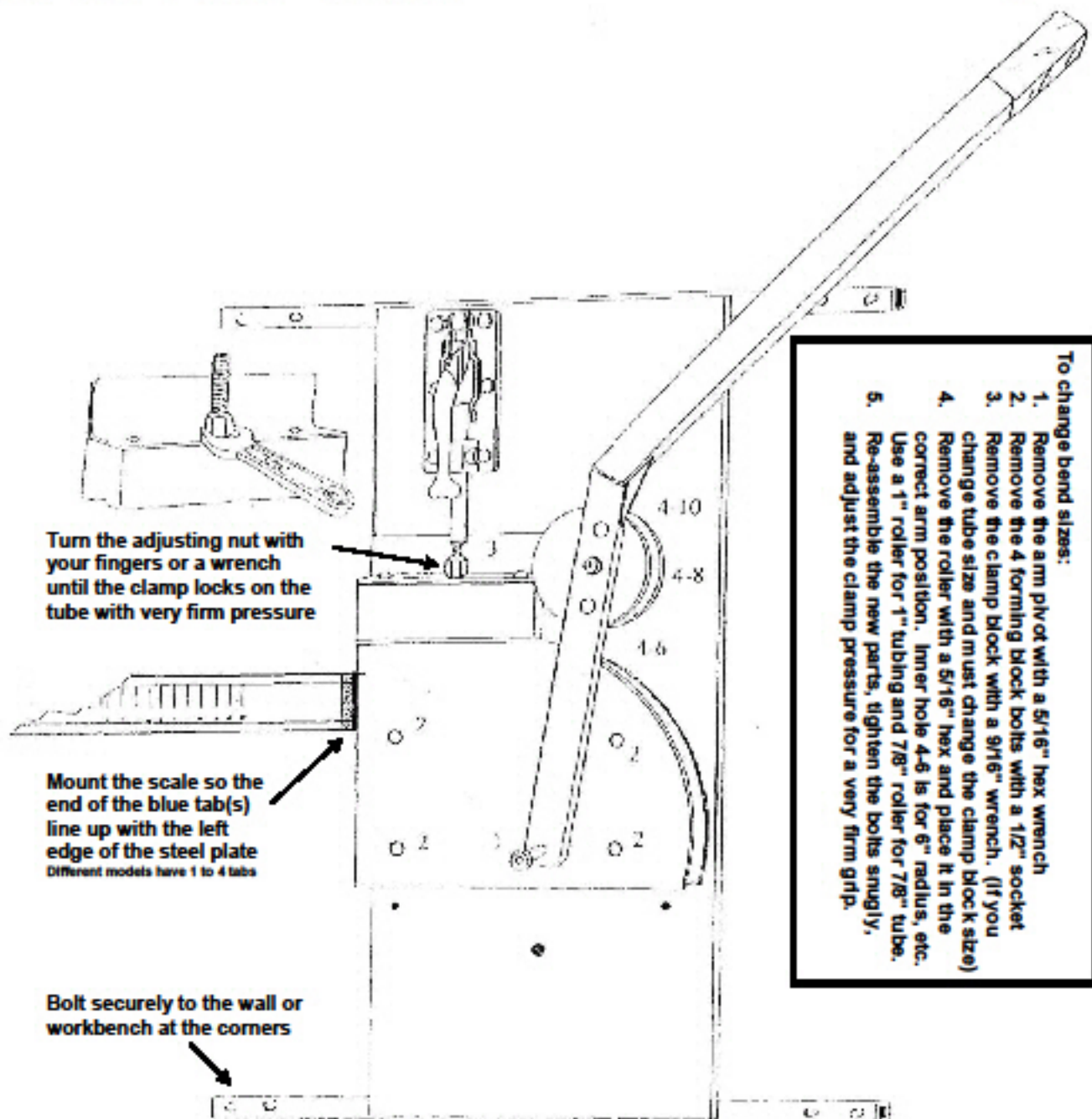

Turn the adjusting nut with your fingers or a wrench until the clamp locks on the tube with very firm pressure

Mount the scale so the end of the blue tab(s) line up with the left edge of the steel plate  
Different models have 1 to 4 tabs

Bolt securely to the wall or workbench at the corners

- To change bend sizes:**
1. Remove the arm pivot with a 5/16" hex wrench
  2. Remove the 4 forming block bolts with a 1/2" socket
  3. Remove the clamp block with a 9/16" wrench. (If you change tube size and must change the clamp block size)
  4. Remove the roller with a 5/16" hex and place it in the correct arm position. Inner hole 4-6 is for 6" radius, etc.
  5. Use a 1" roller for 1" tubing and 7/8" roller for 7/8" tube. Re-assemble the new parts, tighten the bolts snugly, and adjust the clamp pressure for a very firm grip.

**TWO PROPERLY PLACED PIECES OF WOOD CAN MAKE YOUR NEW BENDARC WORK EVEN BETTER**

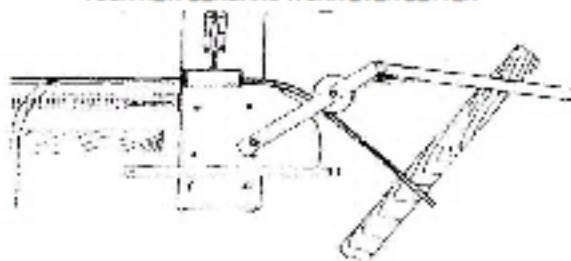

Screw a piece of wood to the wall so that the first bend comes down and lightly rubs against the wood. (Shim the wood out from the wall so the leg just brushes it as you bend.)

Place a second piece of wood on the wall to the left of your Bendarc. Mark sure it is exactly the same thickness with exactly the same shims as the piece on the right.

After you bend the first leg and turn the bow around, make sure it is tight against the left-hand piece. By keeping the first leg tight, the second leg will come down even with the first one.

(You can use washers behind the two boards to make them project out the correct distance. Please use two boards the same thickness with the same number of washers on each board. It's also a good idea to paint or varnish the boards to keep them from warping.)

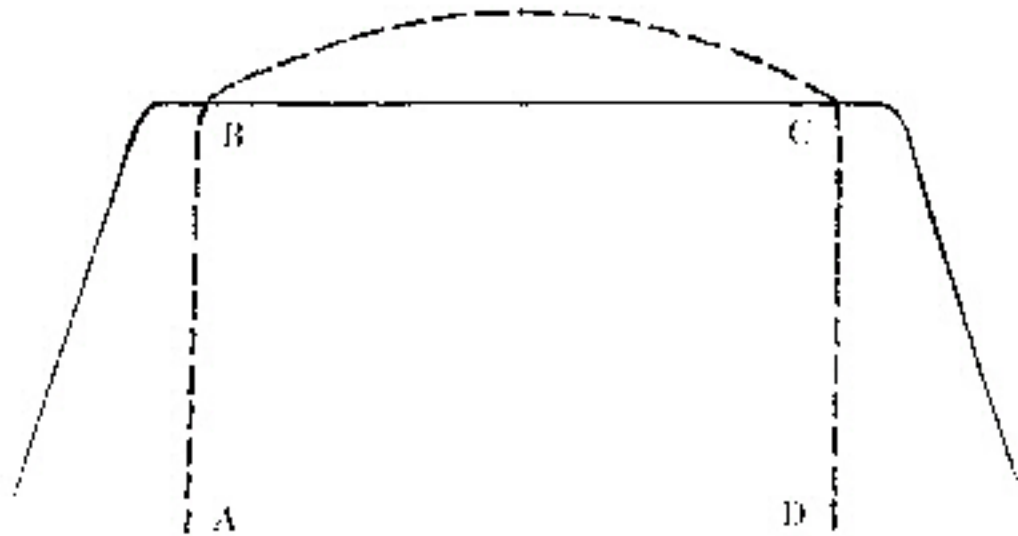

Leave the legs high...  
When you crown, they'll drop  
And the width will shrink.

**Here's a basic way to calculate your bow without crowning:**

1. Measure the distance from A to B, from B to C, and from C to D and total these 3.
2. Subtract from this number:
  - 5" for a 6" radius Bendarc
  - 6<sup>7</sup>/<sub>8</sub>" for an 8" radius Bendarc
  - 8<sup>1</sup>/<sub>2</sub>" for a 10" radius Bendarc
  - 10<sup>1</sup>/<sub>4</sub>" for a 12" radius Bendarc
3. Cut a piece of tubing that long **and mark the midpoint**.
4. Put the tubing in your Bendarc and align the midpoint mark with the number on the scale that's the same as the B to C distance (the width). Clamp & bend a leg.
5. Turn the tube around; **align the width mark again**, and bend the second leg.
6. It's important that the 1<sup>st</sup> leg bent is straight when it's turned so that the 2<sup>nd</sup> leg will come down in line with the 1<sup>st</sup>. Accurate guide boards (see page 1) will help.

#### Additional Tips:

If you crown your bow, you must allow for the arch. The crown (an upward curve in the B to C dimension) allows water to drain off the finished top. Crowning creates 2 changes: The B to C dimension (width) shrinks, and the legs drop.

To allow for the "shrink" in width (B to C), try adding 1/2" for every 15" of width. Example for a bow that's 75" wide:  $75/15 = 5$ .  $5 \times \frac{1}{2} = 2 \frac{1}{2}$ .  $75 + 2 \frac{1}{2} = 77 \frac{1}{2}$ . So in this case measure, cut & bend the bow as if it were 77 1/2" wide, because when you crown the width will shrink toward the 75" you really need. This is a guide not a hard rule. If you want a higher crown, try adding 1/2" for each 12" of width.

Crowning also drops the legs so **leave them high!** You can bend the legs down more, later if needed, but you can't raise them once they are bent.

The greatest problem when bending boat top frames is allowing for the crown. When you crown (rolling in an upward curve for water drainage) the angle of the leg bend increases. (The legs drop.) The overall width also decreases from the upward thrust of the crown, see figure 1. Experienced fabricators have learned, through sometimes expensive trial and error, how to get close. They've learned how to allow for the changes caused by crowning, but even experienced "pros" occasionally misjudge the leg-drop or width-shrink caused by the crown.

Our consultant, Professor Michael Shaevitz of Columbia University, has developed a trigonometric based formula to calculate these two critical variables. This complex formula, which most of us couldn't easily use, has been made more user friendly by Professor Shaevitz's application chart.

### Here's how to bend a bow using the chart:

Suppose you'd like to bend a bow that has a finished width after crowning of 72" with crown height of 8" a leg length of 40" and a leg angle of 90°.

1. Divide the crown height by the finished width.  $8 \div 72 = 0.111$ .
2. Find the number on the top line of the chart closest to 0.111. It is 0.110.
3. Under 0.110 note the angle change - 24.8 or rounded off about 25°.
4. You will "under-bend" the legs by 25°. Instead of a 90° bend, bend them 65°.
5. The last number under 0.110 (1.0320) is the ratio of full width to finished width. Multiply the finished width by the ratio to get the width before crowning.  $72 \times 1.0320 = 74.304$  or about  $74\frac{3}{8}$ ". You will bend your bow  $74\frac{3}{8}$ " wide to get the finished width of 72" after rolling in an 8" crown. You're now ready to measure and cut the tubing.
6. Add the 2 leg lengths to the "before crowning width"  $40+40+74\frac{3}{8} = 154\frac{3}{8}$
7. Deduct for the corner radius of your bender. For example, if you're using an 8" Bendarc deduct  $6\frac{7}{8}$ " as a corner allowance.  $154\frac{3}{8} - 6\frac{7}{8} = 147\frac{1}{2}$ ". Cut off  $147\frac{1}{2}$ " of tubing.
8. Mark the midpoint and align the midpoint with  $74\frac{3}{8}$ " on the width scale.
9. Clamp and bend your leg 65°. Turn the half-bent bow around line up the midpoint on the scale again and bend the other leg to 65°.
10. Insert the corner of the bow in your Crownarc. Drop the center roller 1/2 to 1 turn below level and crank through to the other corner. Drop the center again and continue to "rock" back and forth until you have the 8" crown.

The crown 'shrinks' the width to 72" and 'drops the legs to 90°.

