

# FrameBenders.Com - part o King Richard Co.

Ph: 978-687-9175 Email – [Info@KingRichard.Net](mailto:Info@KingRichard.Net)

March 2011

## Bendarc Quick-Switch Sizes & Prices

	<u>7/8" or 1" round</u>	<u>1 1/4" round</u>	<u>1" square</u>
<b>Bendarc 6" radius</b>	\$450		
<b>Bendarc 8" radius</b>	\$504		
<b>Bendarc 10" radius</b>	\$564	\$789	\$699
<b>Bendarc 12" radius</b>	\$639	\$867	\$768

Note: 1" square and 1 1/4" round models have the forming block **encased in steel plate** for extra strength and long life.  
1 1/4" round has a longer, stronger, super-duty bend arm.

**Bendarc Quick-Switch** professional benders

have interchangeable dies for tube size and radius.

The following parts allow you to change tube and radius sizes:

## Bendarc Quick-Switch Parts List

<b>Forming Blocks</b>	<u>7/8" or 1" round</u>	<u>1 1/4" round</u>	<u>square</u>
6" radius	\$120		
8" radius	\$180		
10" radius	\$234	\$669-7 pc kit	\$390
12" radius	\$312	\$732-7 pc kit	\$450
<b>Bendarc Roller</b>	\$45	\$51	\$51
<b>Clamp Block</b>	\$36	\$45	\$36

Bend Arm-\$162 HD Bend Arm-\$171 Scale with Instructions-\$21

**Bendarc** Back-Plate w. mount arms & weld-nuts, powder-coated \$249

When ordering a forming block in a **different tube size** for your **Bendarc Quick-Switch**, you also need a clamp block and roller in that size. Older **Bendarc**s will not accept Quick-Switch parts. Quick-Switch models have square steel pull-down arms with 3 or 4 roller positions.

Older, 3 position arms cannot use 12" radius.

A 10% discount applies to additional Q-S parts ordered with a Bendarc.

**Bendarc** rollers have high-strength steel sleeve bearings for long life.

**Bendarc** is available in a double, high-production, sliding model.

## Crownarc Sizes & Prices

	<u>7/8" and 1" round</u>	<u>1 1/4" round</u>	<u>1" square</u>
<b>Crownarc 3 roller</b>	\$417	\$495	\$459

crank drive crowner

w.extra large gears

**Crownarc**s for round tube roll any round size smaller than the stated size.

## Crownarc Parts List

	<u>1" &amp; 7/8" round</u>	<u>1 1/4" round</u>	<u>square</u>
Center Roller w bearing	\$51	\$60	\$60
Outer Roller-not mounted	\$48	\$57	\$57
Outer Roller-gear mounted	\$66	\$99 extra lg gear	\$75
Slide Block Assembly-3 pc	\$39 (New style-minimizes wobble)		
Hand Grip	\$24 (New style-polished, heavy duty)		
Crank Arm	\$42 (pre bent, drilled, powder coated)		
Back Plate w Weld Nut	\$162 (powder coated)		

Older **Crownarc**s will accept square rollers if they have 3/4" roller shafts, 8 3/8" on center between the lower rollers & 1 1/4" rollers with larger gears if there are 2 extra roller mount holes visible from the rear of the Crownarc.

This price list, dated March, 2011, supersedes all previous prices.

Specifications and prices are subject to change.

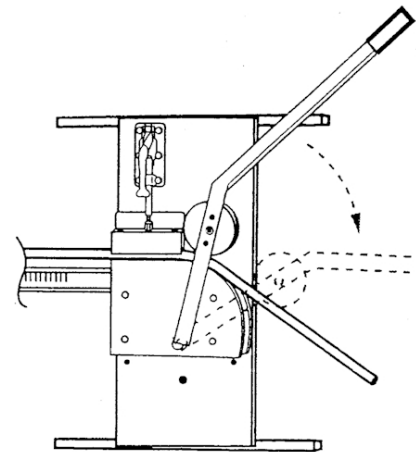

**Bendarc Tool**

Proportions vary by radius size.

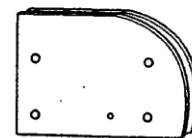

**Forming Block**

Some models are steel cased.

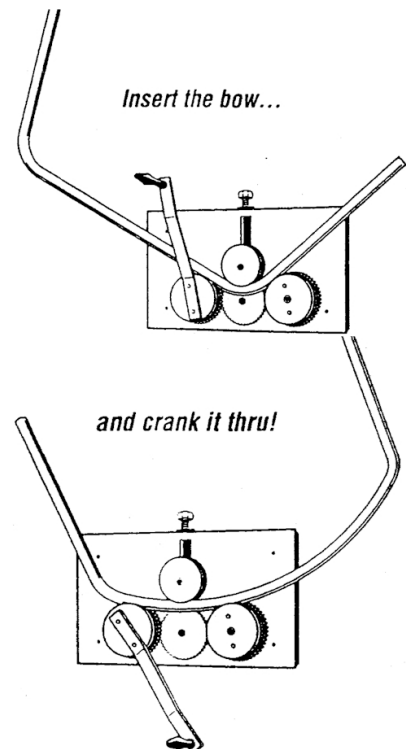

**Crownarc Tool**

1 1/4" model has extra large gears.